



**ÇÖZÜMARGE**  
Bilişim Hizmetleri

# User Manual

## Plock 1 Remote parking lock

---

Version: 1.0

Date: March, 2018



# Content

1. Brief Introduction .....	
1	
2. Specification .....	1
3. Function & Feature .....	2
4. Structure .....	
2	
5. Installation .....	2
6. Battery cautions .....	3
7. Use cautions .....	3
8. Trouble removal .....	4
9. Packing list .....	4

# 1. Brief Introduction

Plock 1 is ZKTeco first generation parking lock, combined with years of practical experience and industry accumulation of technology, it can achieve the private parking management. Compared to the traditional manual parking lock, Plock 1 provides a smart, convenient and perfect user experience. It is widely used in residential, corporate buildings, industrial parks, hotels, airports and other parking management.

# 2. Specification

Model	Plock 1
Material	SPCC steel
Control distance	≤20m
Arm rising time/falling time	≤6s
Altitude after rising	390mm
Altitude after dropping	75mm
Operating temperature	-10°C ~+55°C
Power supply	Alkaline dry battery (D x 4)
Rated voltage	DC6V
Quiescent current	≤0.1mA
Operating current	≤0.9A
Size	390mm x 460mm x 75mm
Weight	8KG

### 3. Function & Feature

- Long distance remote control: Remote control distance up to 20m.
- 180° Anti-collision, built-in anti-collision alarm system: Buzzer alarms as long as arm is moved by external force, and with the external force down swing, arm automatically reset 3-5 seconds after external force cancelled.  
2-3T High pressure resistance: Can withstand 2 tons of car rolling without damage.
- Protection class: IP67
- Low battery automatically prompts: If the built-in battery power is low, buzzer will alarm and Led light will flash.
- Anti-theft: The key components of the lock inside the housing, which need to use the key to open.
  
- 

### 4. Structure

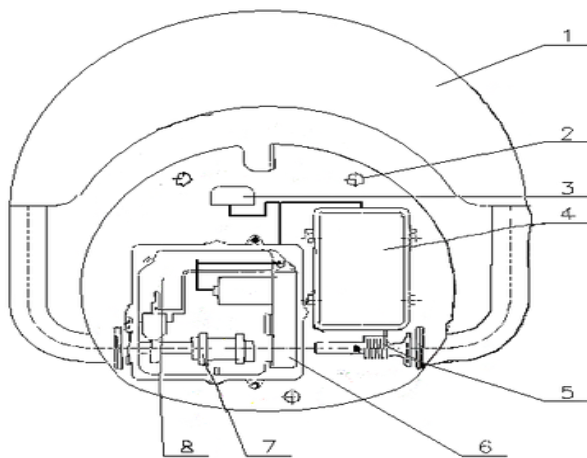

- |                 |                         |   |
|-----------------|-------------------------|---|
| 1 Arm           | 5 Energy saving device  | 6 |
| 2 Mounting hole | 3 Motor                 |   |
| Alarm           | 7 Anti-collision device |   |
| 4 Power supply  | 8 Control system        |   |

### 5. Installation

Before installing the parking lock, confirm the equipment inside the box is intact, and make sure the ground is concrete and smooth.

**Installation tool:**

Impact drill, drill bit No. 8, No. 8 expansion screw, hex wrench, ordinary hammer.

### **Installation step:**

1. Pull up the parking lock arm, unlock and remove the top cover.
2. Determine the parking lock installation position, and place the parking lock on the position.
3. Use pen to mark the three holes to confirm drilling positions.
4. According to the position of the three mounting holes, with the model M12 drill bit, drill three diameter 12mm, 80mm deep hole, and knock the expansion bolt M8 into the hole, and then remove the nuts.
5. Thread the three holes through the expansion bolt and tighten the nuts.
6. Connect the battery plug and lock the top cover.
7. Start operating the parking lock. If the parking lock operate normally, that is, the installation is completed.

## **6. Battery cautions**

1. The factory default is not equipped with batteries. Please use alkaline dry batteries (D x 4).
2. Do not heat, disassemble the battery.
3. Do not reverse the battery polarity.
4. Do not put the battery into fire or try to open it.

## **7. Use cautions**

1. When the remote controller is lack of power, the same type of batteries should be replaced in time.
2. Regularly clean the surface of the dust and garbage, try to ensure that the parking lock clean and dry.

## 8. Trouble removal

### □ Power on but no power prompt.

1. Low battery or damage, replace the same type of batteries.
2. Poor power cord connection, tighten or replace the power cord.
3. Host control box damage and replace it.

### □ Remote control short distance or remote control failure.

1. Low battery, replace the battery.
2. Host control box damage and replace it.

### □ Arm is not in place, and no external force but alarm.

1. Limit switch loose. Fine tune the limit switch and tighten the screw properly.
2. There is an object in the rotation of the arm or the spindle. Remove foreign body
3. Transmission damaged and replace it.

If you can't solve the problem, contact the supplier.

## 9. Packing list

Serial NO.	Name	Quantity
1	Parking lock	1PCS
2	Instruction	1PCS
3	Remote controller	2PCS
4	Key	2PCS
5	Expansion bolts	3PCS