



ÇÖZÜMARGE
Bilişim Hizmetleri

Ofis Adres



Perpa Tic. Merkezi A Blok Kat 5 No :174-176 Okmeydanı – Şişli / İSTANBUL



Telefon: 0850 733 63 22



Email: info@cozumarge.com

SBT1000S series user manual

Version: 1.0 Date: August, 2016

Chapter 1 Brief introduction

This paper introduce SBT1000S series' installation and commissioning.

1.1 Chassis

SBT1000S series use the stainless steel housing, simple and beautiful, anti-corrosion and anti-rust proof. Chassis size see Figure 1-1.

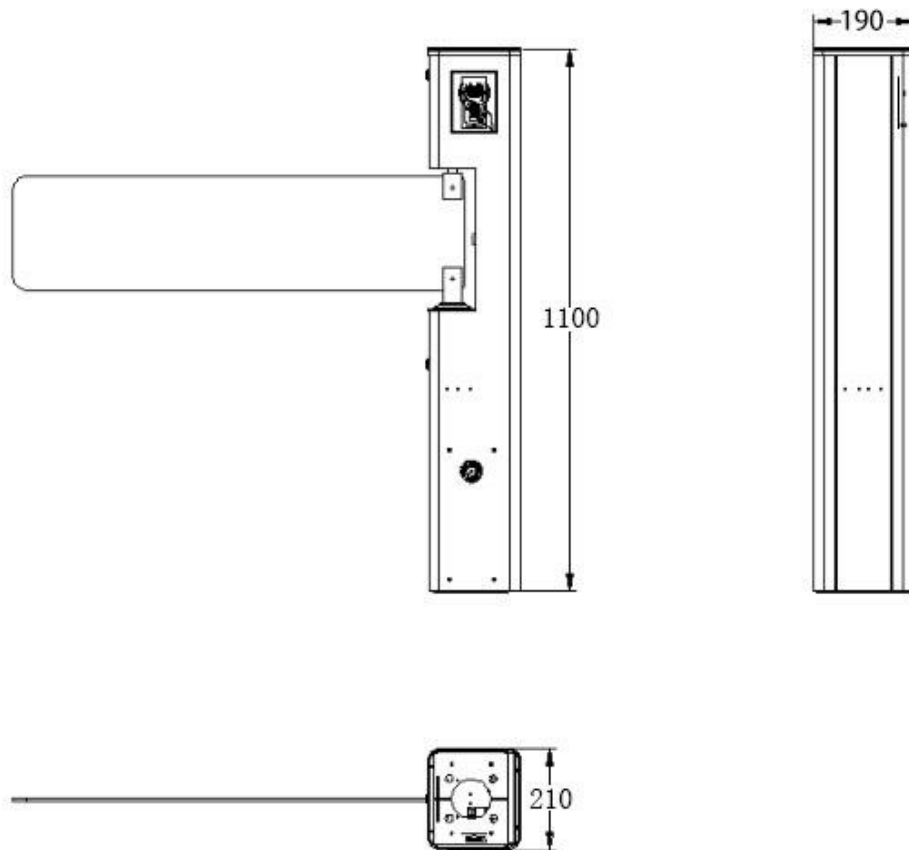

Figure 1-1 (mm)

1.2 Speed gate barrier or arm

There are two types of barriers or arms for the SBT1000S. The glass arm see Figure 2-1, the stainless steel bar arm see Figure 2-2.

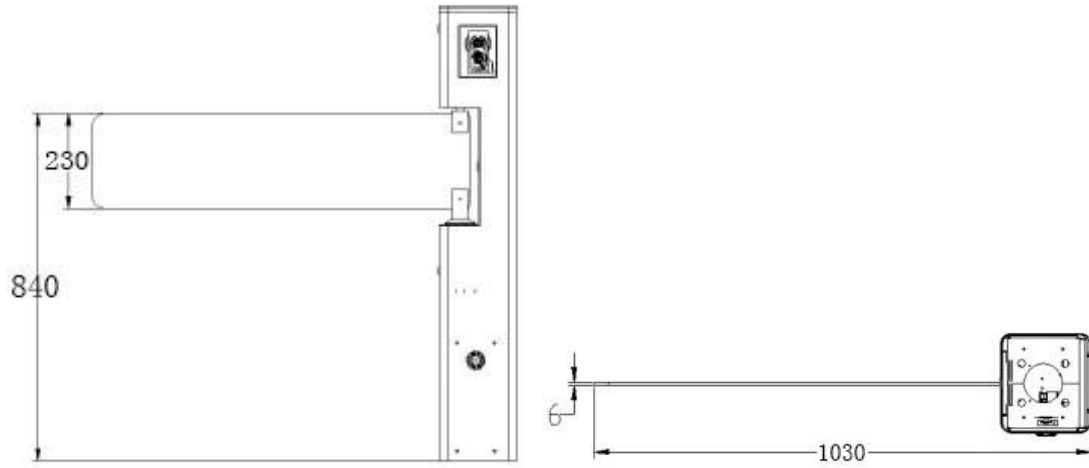

Figure 2-1 (mm)

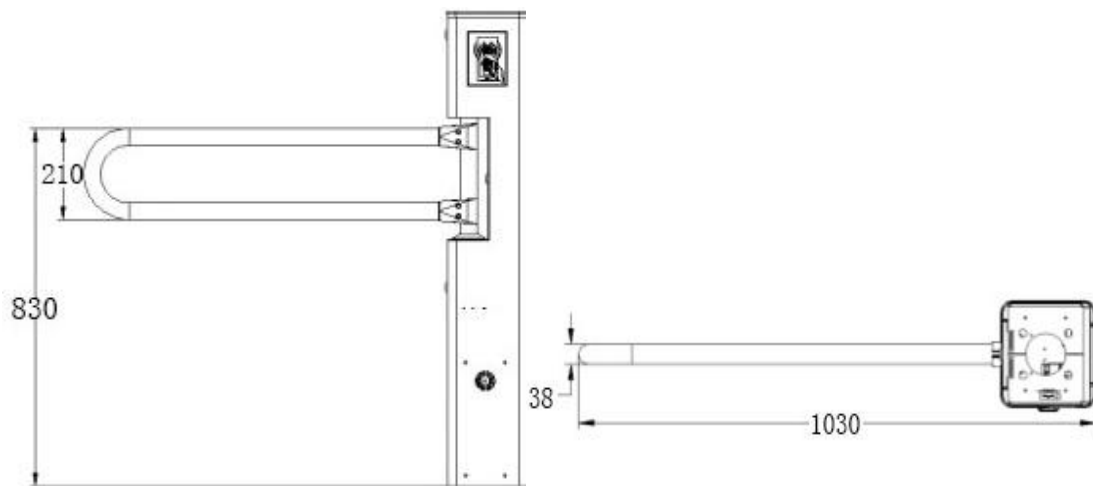
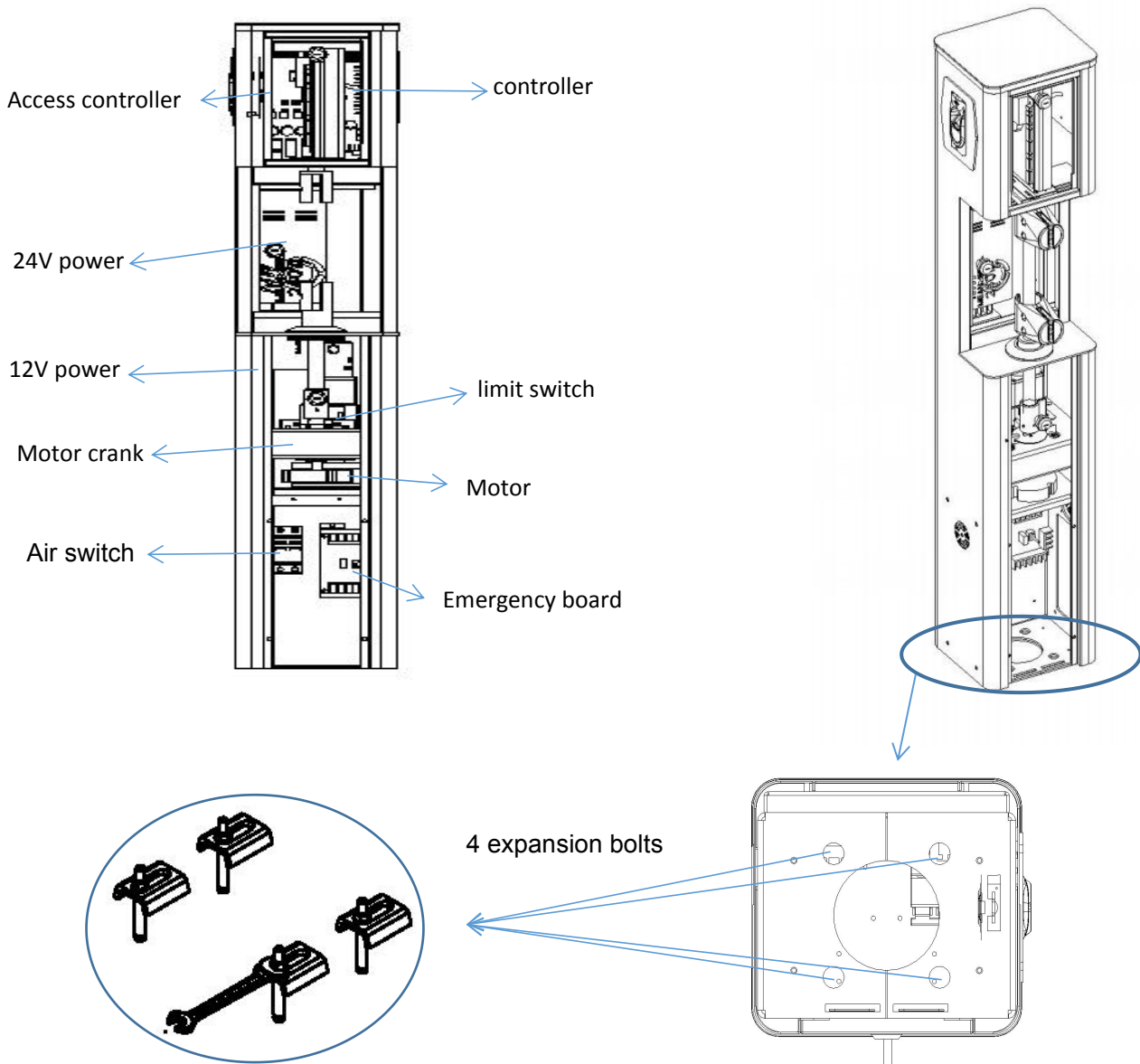

Figure 2-2 (mm)

1.3 Chassis inner components



1.4 Mechanical system

The mechanical system consists of a motor, a crank and a barrier arm. Forced by the motor through the crank, the arm acts based on the signal.

1.5 Electric control subsystem

The electric control system consists of a reader, control board, infrared sensor, alarm apparatus, limit switch and power supply installed on the cabinet.

1. **Reader** (optional) : Read the user information from cards or fingerprints, and transmit the information to the control board.
2. **Control board** : Control center of the system, receive information form the reader and infrared sensor, deal with the information and send the command to motor, counter, indicator light or alarm.
3. **Infrared sensor** : Detection and protection of pedestrians in the passageway.
4. **Alarm apparatus**: Giving sound and light alarm when detect intrusion.
5. **Limit switch** : Control the rotation angle of the gate.

1.6 Specifications of SBT1000S series

Appearance	Model	Reader Device	Gate Standard Width	Open/Close Time	Dimensions	Angle Range
Stainless steel silvery appearance series	SBT1000S	\	850mm	1-2s	L=210mm W=190mm H=1100mm	180°
	SBT1011S	RFID				
	SBT1022S	Fingerprint and RFID				

Chapter 2 Product installation

2.1 Working principles

1. Equipment automatically starts self-checking program when power is on, gate will close automatically.
2. Reader transfers the user information to the control board, and incepts the feedback information.
3. Control board receives and compares information with the data stored in our client database, according to the handling result, controller sends command to drive the motor.
4. The infrared sensor continuously detect until pedestrians pass through the barrier.
5. The buzzer sounds when detect intrusion is detected.

2.2 Installation precautions

1. Do not push the barrier arm when it is closed.
2. Do not sit on the barrier arm.
3. Install the device 50-100mm higher than the concrete platform.
4. Do not expose the product in the rain or corrosion environment to prolong its service life.
5. Ensure that the system is grounding before use to avoid security accidents.
6. Please keep the device surface clean and dry, do not clean with water to avoid short circuit of electric system.
7. Regularly check the electric system and mechanical system to make sure good connecting and operating.

2.3 Cable embedding

Before cable embedding, the machine should be posited on the level and solid ground. If the ground is uneven or the foundation is loose, a concrete construction is necessary. Make notch on the ground between the machine and the control room, and then embed the cable with protective sleeves. Finally backfill the notch after test.

Protective sleeve: $\phi 25$, black

Cable Standard: RVV3*1.0

Attention: The power wire should be protected with sleeve.

The signal line should be kept away from the power wire.

2.4 Chassis installation guide

1. Verify the accessories on the list and gather tools.
2. Posit the machine on the right place.
3. Drill on the ground according to the positioning tape .
4. Embedding four expansion bolts (M12) into the positioning holes.
5. Remove the access cover, as shown in Figure 2-4A.
6. Put pads and use a wrench to tighten nuts, as shown in Figure 2-4B.
7. Close the access cover, as shown in Figure2-4C.
8. Install the barrier arm(glass baffle or U-shaped stainless steel pipes), as shown in Figure2-4D.

1

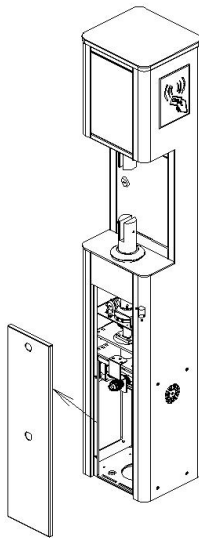

Figure 2-4A

2

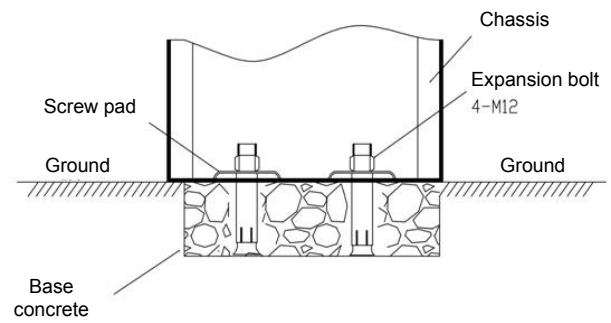

Figure 2-4B

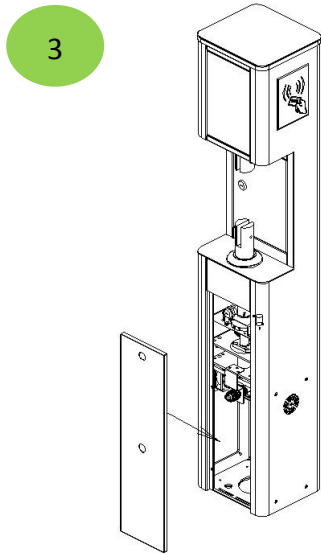

Figure 2-4C

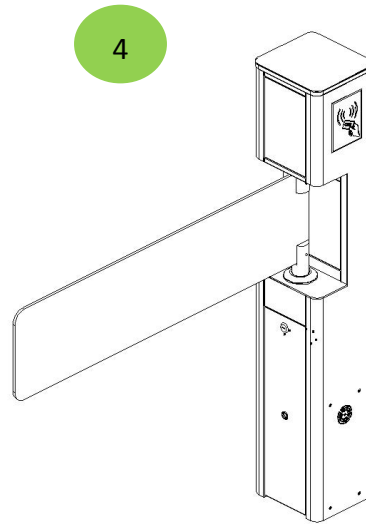

Figure 2-4D

2.5 Barrier arm installation

The barrier arm can be fixed on the chassis with provided screws. Keep it perpendicular to the ground and fixed tightly. If fork-shaped rod is needed, check device adjusted vertical and horizontal properly, and move the barrier arm to the horizontal position with hands. Locate installing place for fork-shaped rod end of arm, and fixed with screws.(Do not install if not needed).



← U-shaped stainless steel pipes

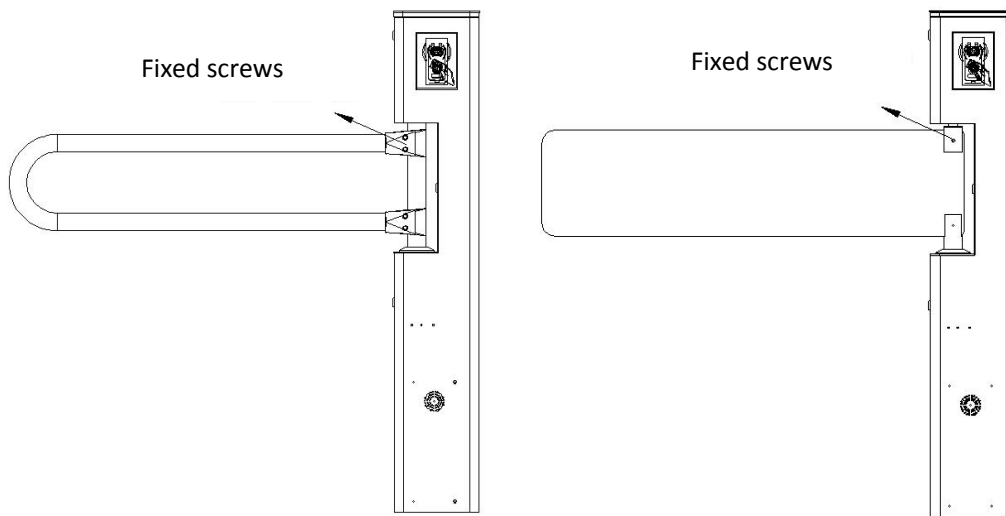

2.6 System design

2.6.1 Design objectives

1. The system design meets the national and personnel management safety standards.
2. The system adopts advanced pedestrian entrance management mode.
3. The system has good performances on security.
4. The system can managed online or offline.
5. The system is industrial structured and configured flexibly.

2.6.2 System diagram

Installation diagram for the barrier gate:

1. The distance between the chassis and the wall should be greater than or equal to 100 mm.
2. The distance between the arm and the wall should be greater than or equal to 100 mm.

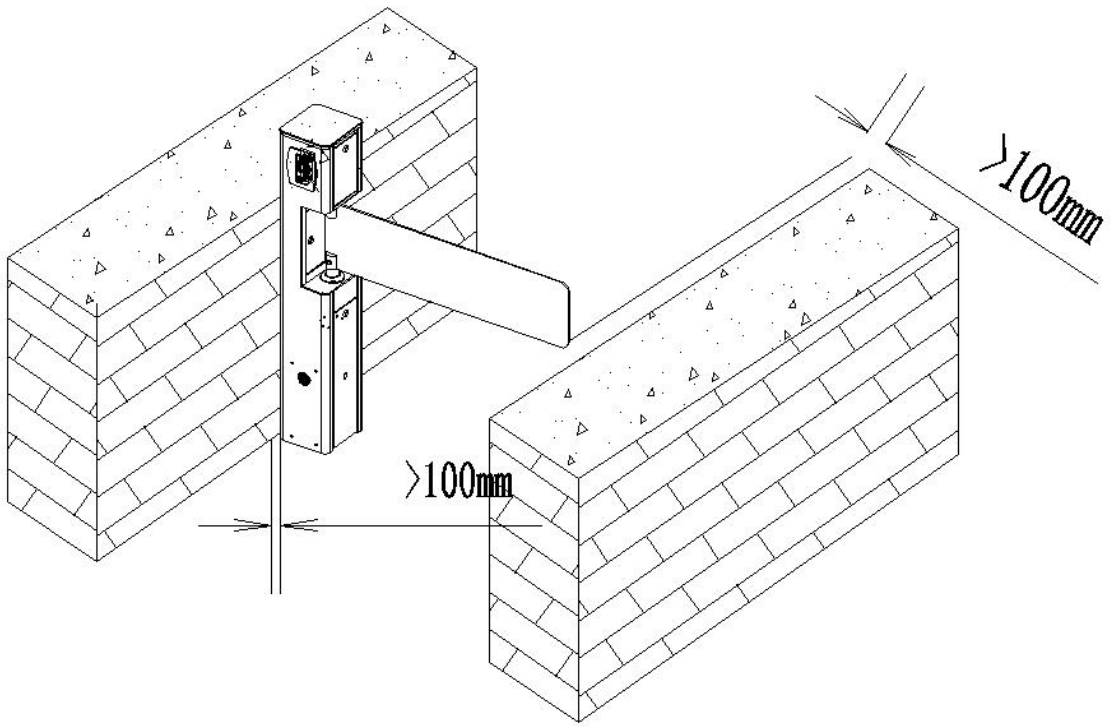

Chapter 3 Device commissioning

3.1 Commissioning preparations

Follow the wiring diagram accurately for wiring, then turn the power on.

3.2 Commissioning project

1. The gate is a two-way pass, can be set normally closed or normally open.
2. Power on self-check function : Automatically start self-checking program when power on, and reset the barrier arm be reset.
3. Anti-collision function : Gate will open forward when verify successfully even though you already activate the infrared alarm, and close soon after passing through. But passing from the opposite direction, the gate will not open.
4. Anti-pinch function : Through the sensor, the machine can sense the pedestrian in passage way. In the closing process, the arm will be opened forcibly if detect the pedestrian. The barrier arm closes only when the sensor detects no pedestrian.
5. Alarm function : Alarm when detect intrusion.
6. Anti-tail function : Only allows one pedestrian through the passage under condition of one card. Alarm if sensor detects pedestrian without the card.
7. Reverse entry alarm function : Alarm when reverse entry.
8. Emergency function : The system operates via battery when the power failure.

3.3 DIP switch K1-8 setting

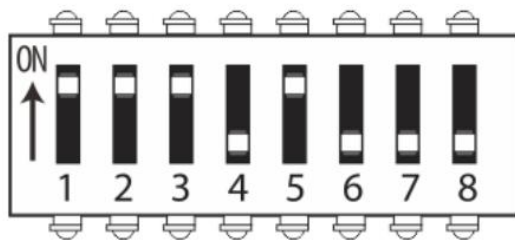

NO.	K1-1	K1-2	K1-3	K1-4	K1-5	K1-6	K1-7	K1-8
Function	Flap open duration			Open direction		Reserved	Reserved	Arm status
Default	1	1	1	0	1	0	0	0

Flap open duration:

Speed gate barrier will be opened after receiving open signal from access control system.
The gate open duration refers to the opening time of the door without passer-by.

Flap open duration	K1-1 K1-2 K1-3	Flap open duration	K1-1 K1-2 K1-3
5s	1 1 1	30s	0 1 1
10s	1 1 0	40s	0 1 0
15s	1 0 1	50s	0 0 1
20s	1 0 0	60s	0 0 0

Open direction:

K1-4	K1-5	Lane status
0	1	Two-way available
1	0	One-way available(in)
1	1	One-way available(out)

Arm status:

K1-8	Arm status
0	Normal close
1	Normal open

Chapter 4 Common FAQs

NO.	Failure phenomena	Solutions
1	Direct indicator light is not bright	Check the indicator wiring whether it connects correctly.
2	The arm continuously rotates when power on or not limit after open	<ol style="list-style-type: none"> 1. Check Limit Switch : Check whether the power supply is normal ; 2. Check photoelectric Switch: Put a metal plate close to the detected surface. If the indicator lights then you should adjust the switch position, if not, you should replace the switch.
3	The arm does not give response after authentication. The indicator light works normally.	<ol style="list-style-type: none"> 1. Check the electric motor whether it is in well-connected. If wiring is correct, touch the end of the electric motor to determine its operation. If not, replace the main board. 2. Check the signal connection on the control board and check the indicator light to judge if the control board has received the signal. 3. If all of the indicator light on board is not bright, and the power is correctly connected, then the board is damaged.
4	The arm does not reset or reset immediately after being opened.	<ol style="list-style-type: none"> 1. Arm reset time-delay after pedestrians are passing, it indicates the photoelectric switch operates abnormally. 2. Check whether the grating plug malfunctions, 3. Check the switch setting on board.
5	The arm reset after a long time.	<ol style="list-style-type: none"> 1. Check the switch K1-3 . 2. Check whether the Photoelectric switches terminal output 12V signal(0V in Normal).

Chapter 5 Device maintenance

5.1 Chassis maintenance

The chassis is made up of 304 stainless steels and electrolytic steel plates. There may be rust stains on its surface after using for a long time. Regularly sand the surface along the grain softly and carefully. Coat the surface with anti-rust oil. Do not cover the infrared sensor.

5.2 Machine movement maintenance

Cut off power supply before maintenance. Open the lid, clean surface dust, apply butter to the transmission part. Remove the motor, grease the wheel gear, fixed motor on the original position. Check and tighten the connection parts. Do not adjust the limit switch.

5.2 Power supply maintenance

Cut off power supply and clean surface dust. Check and tighten the loose parts. Check and replace the damaged wire. Check the technical parameters of each interface. Timely replace aging electronic components.

Attention : Above repairs and maintenance should be taken by professional technicians. Make the *Device Maintenance Records*.

Appendix 1: Packaging list

Glass gate		
1	Barrier gate	1pc
2	Barrier arm	1set
3	Key	2pcs
4	Instruction book	1pc
5	Installation positioning tag	1pc
6	Hardware pack	1set
7	M12 expansion bolt	4pcs
8	Screw pad	4pcs
9	Glass fixing clip	2pcs
10	Glass clamp	2pcs
11	EVA patch	2pcs

Stainless steel pipes		
1	Barrier gate	1pc
2	Barrier arm	1set
3	Key	2pcs
4	Instruction book	1pc
5	Installation positioning tag	1pc
6	Hardware pack	1set
7	M12 expansion bolt	4pcs
8	Screw pad	4pcs
9	Zinc alloy clip	2pcs
10	Glue	2pcs
11	screw and nut	2pcs

Appendix 2 Wiring diagram of the control board

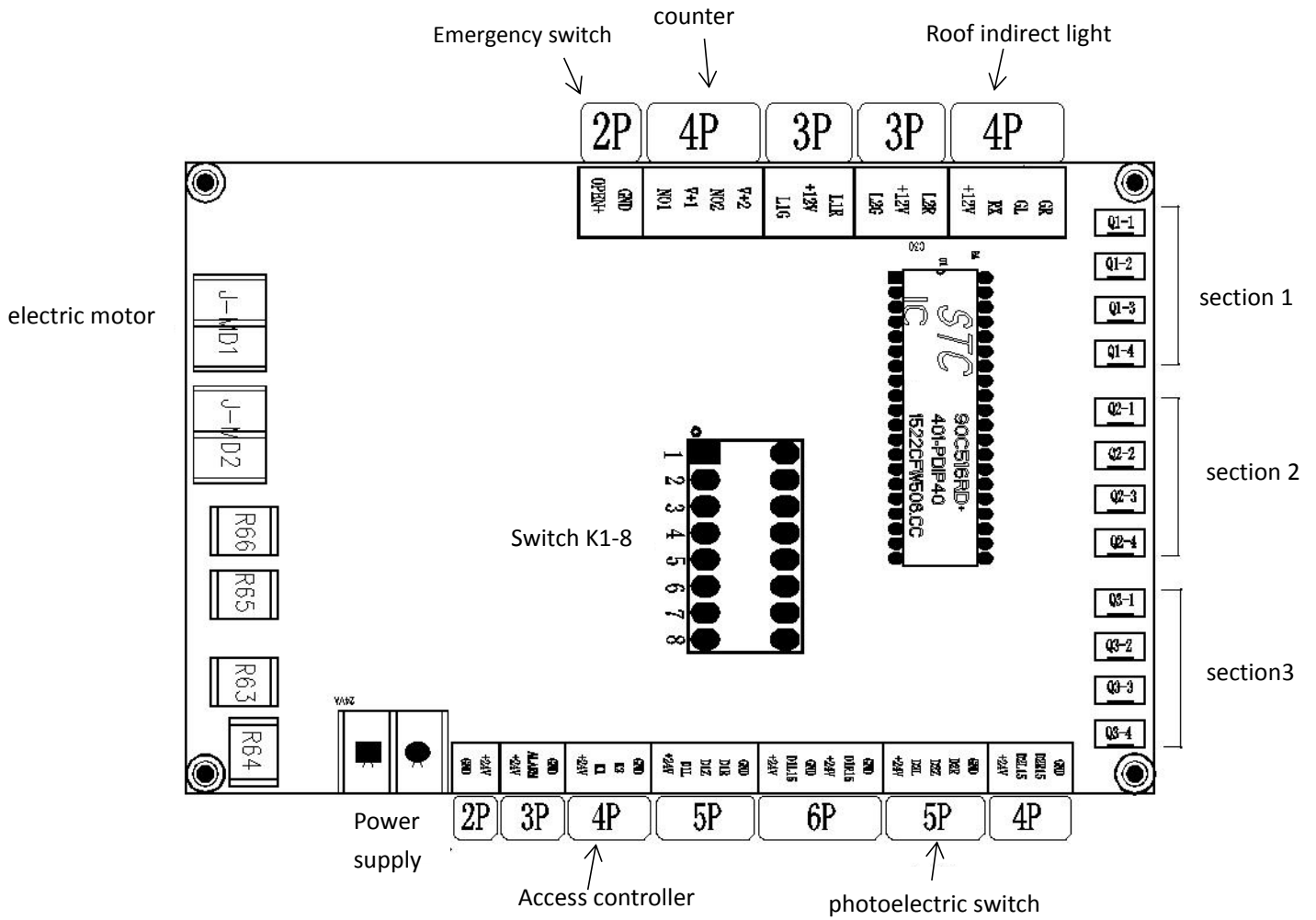

Attached Figure – A Control board diagram

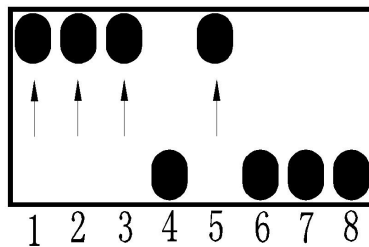
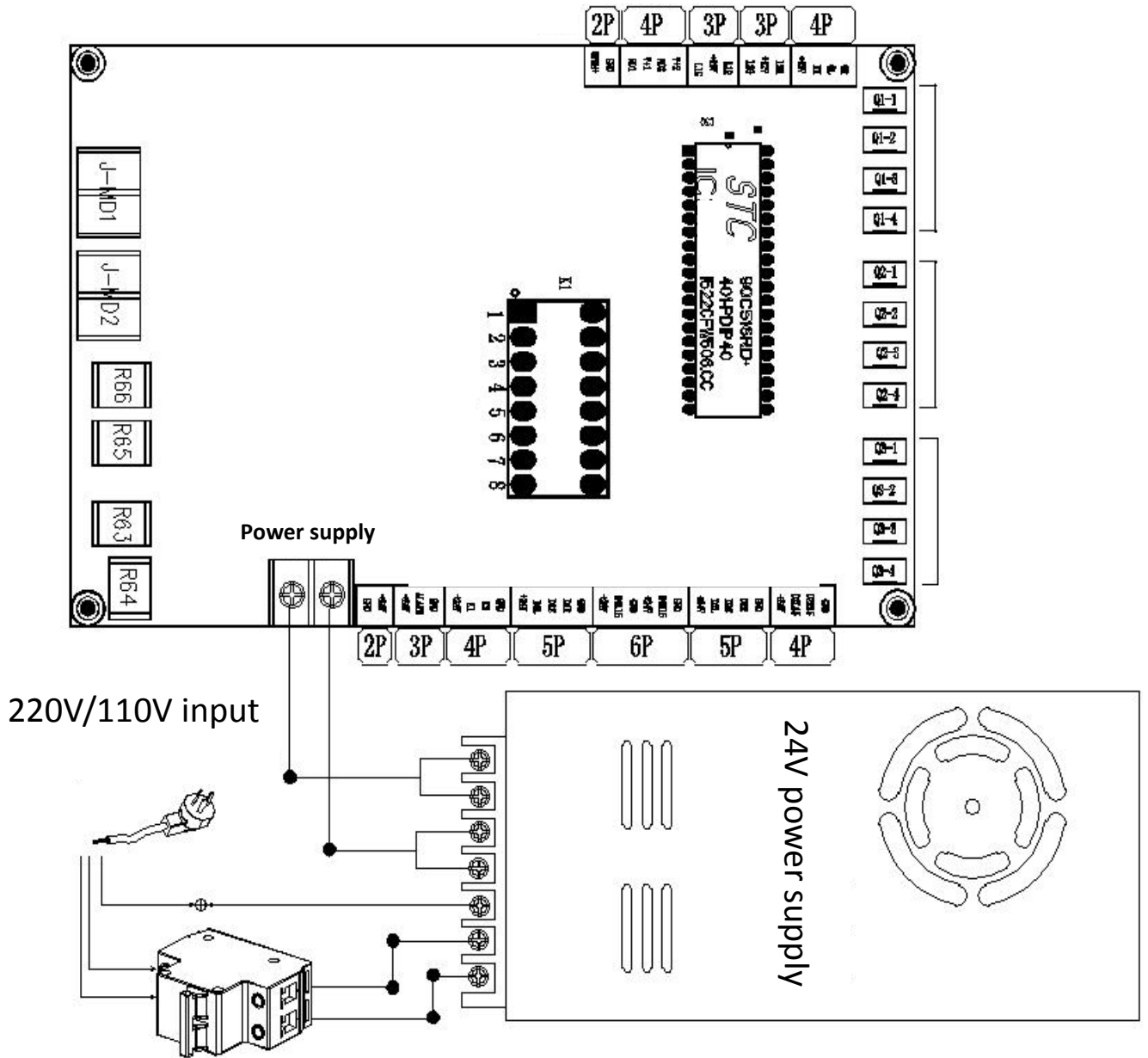
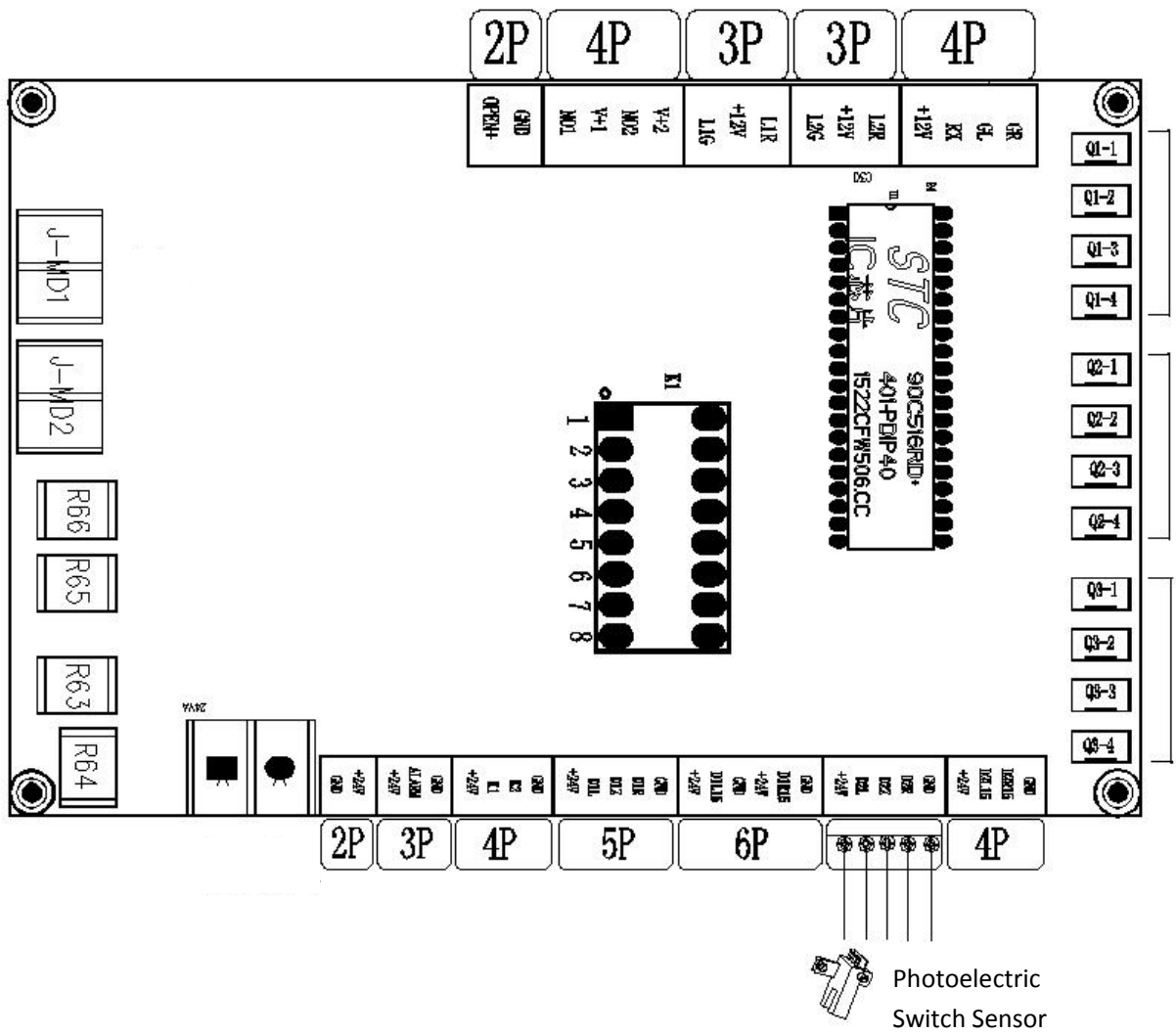

Figure - The default settings of switch



Attached Figure – B Main supply diagram



Attached Figure – C Photoelectric switch sensor wiring diagram

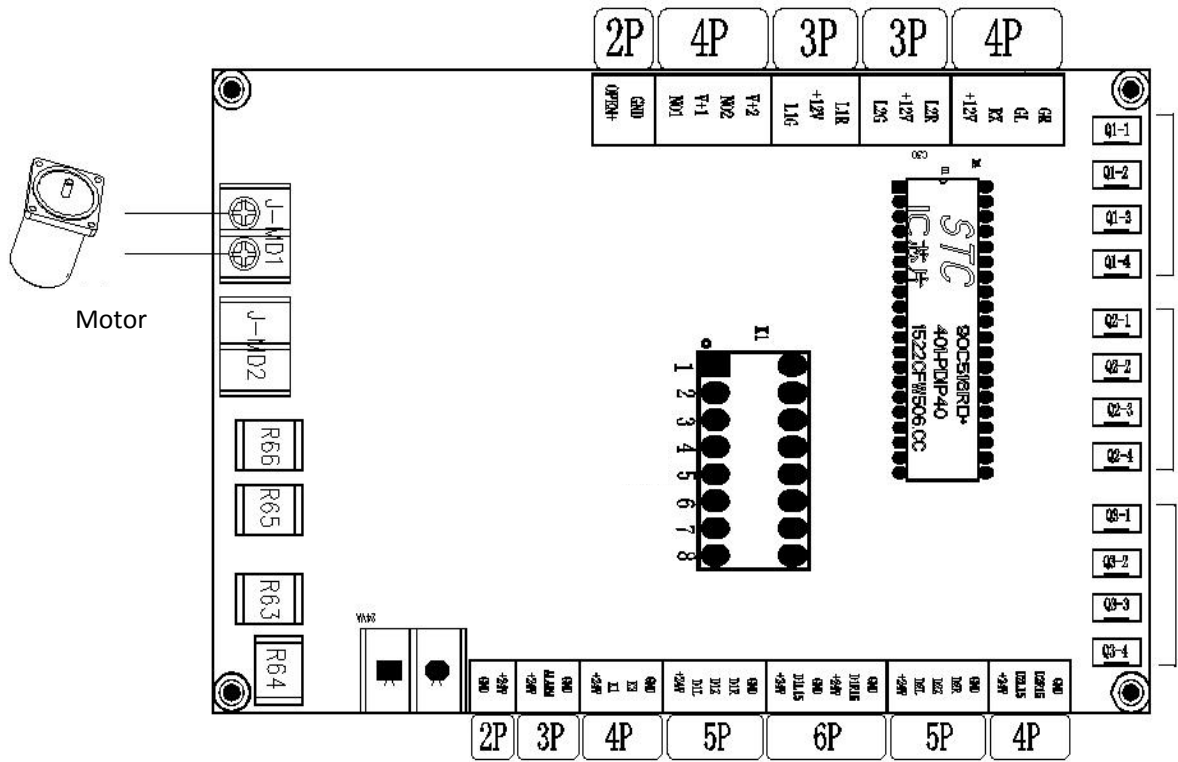

Attached Figure – D Motor wiring diagram

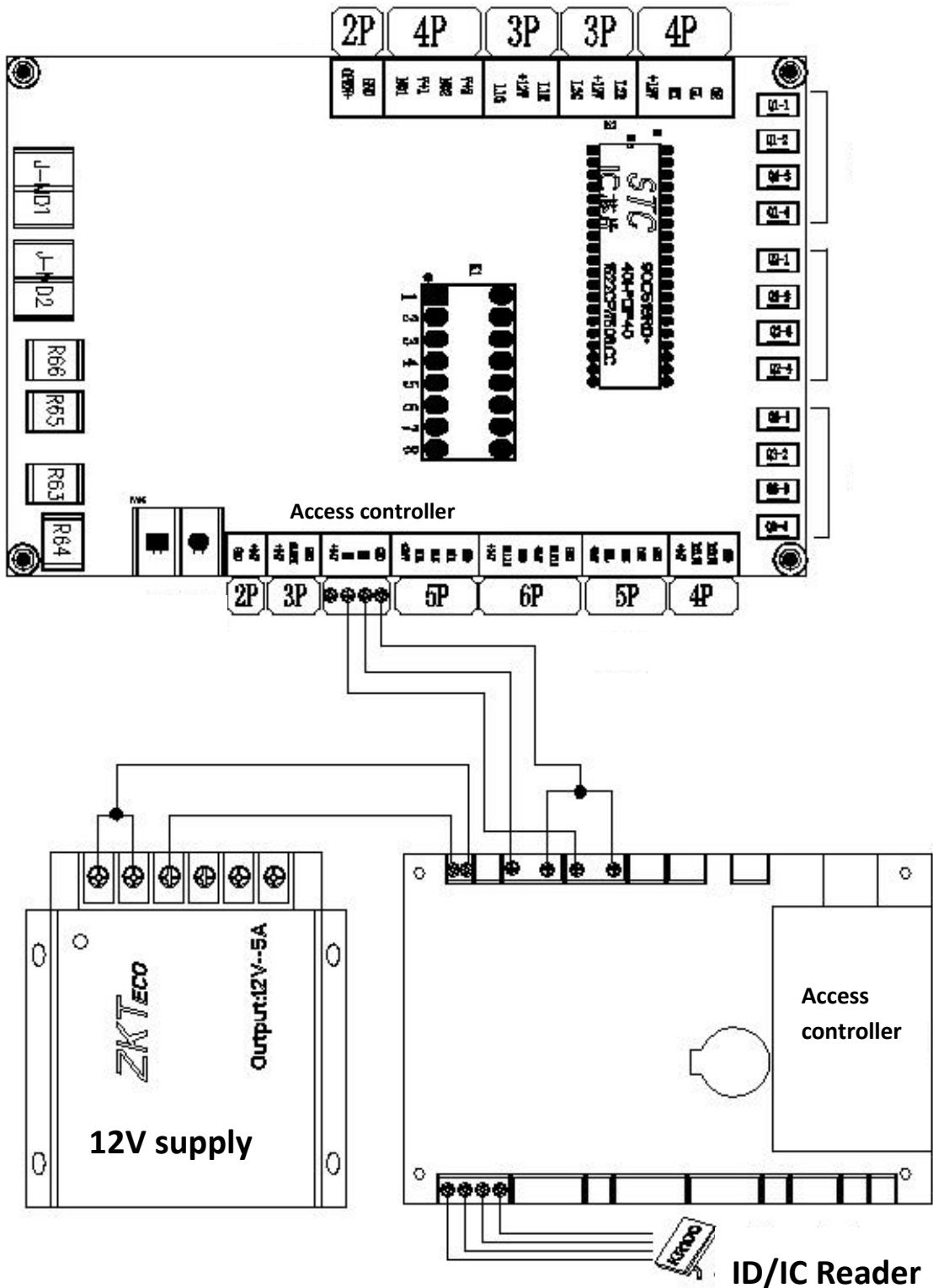

Attached Figure – E ID/IC reader wiring diagram

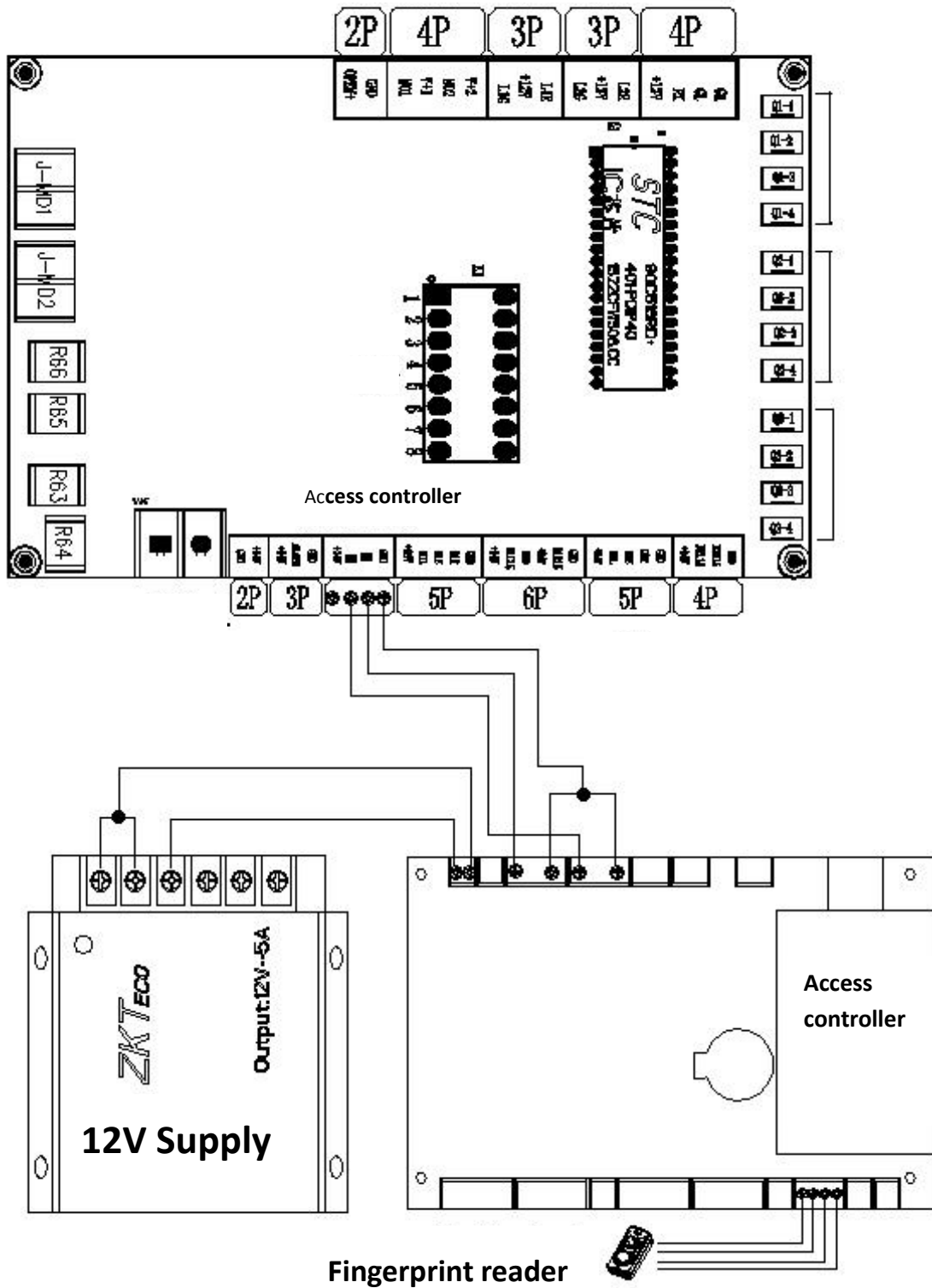

Attached Figure – F Fingerprint reader wiring diagram

Appendix 3 Wiring diagram of the emergency processing system (optional)

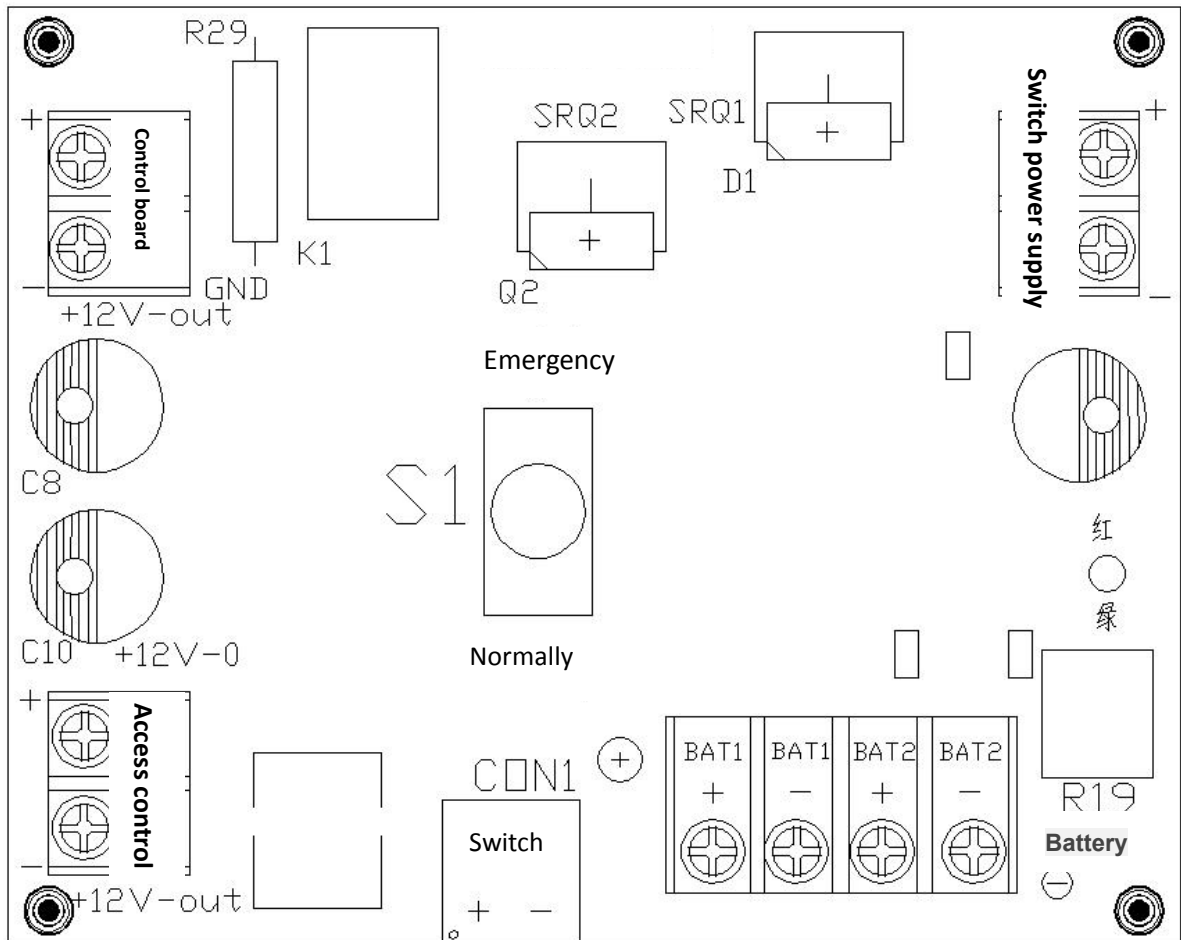

The function of the emergency processing control board:

1. When AC power supply, the speed gate barrier will operate normally.

2. When the power failure:

① S1 set to Emergency mode: the arm will open and control board and access controller power supply will be cut off. The barrier back to normal state until AC power supply return to normal.

② S1 set to Normal mode: The barrier operate normally until the battery voltage is lower than the standard voltage. The control board and access controller power supply will be cut off . The barrier back to normal state until AC power supply return to normal.

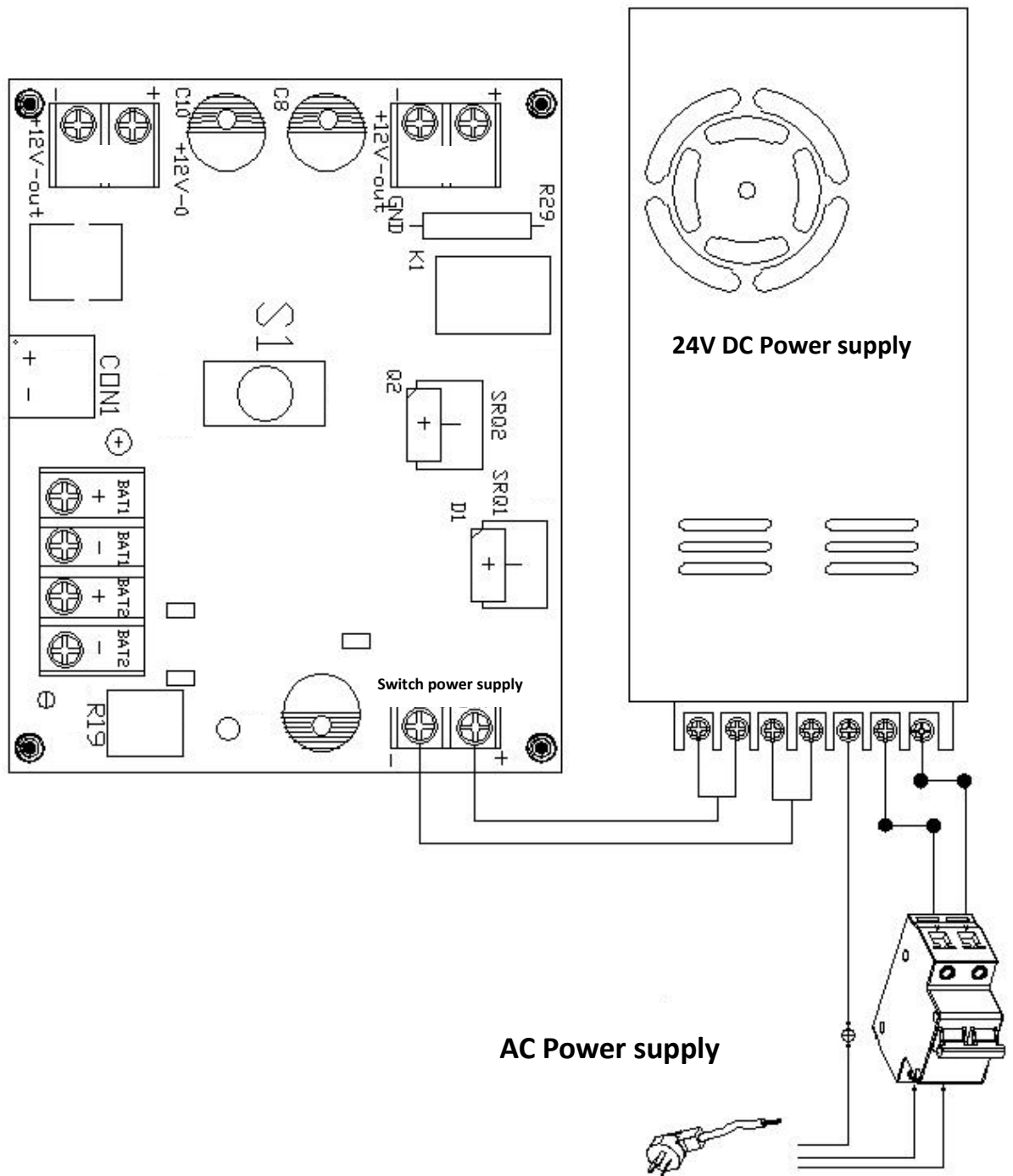

Attached Figure – H Input AC power wiring diagram

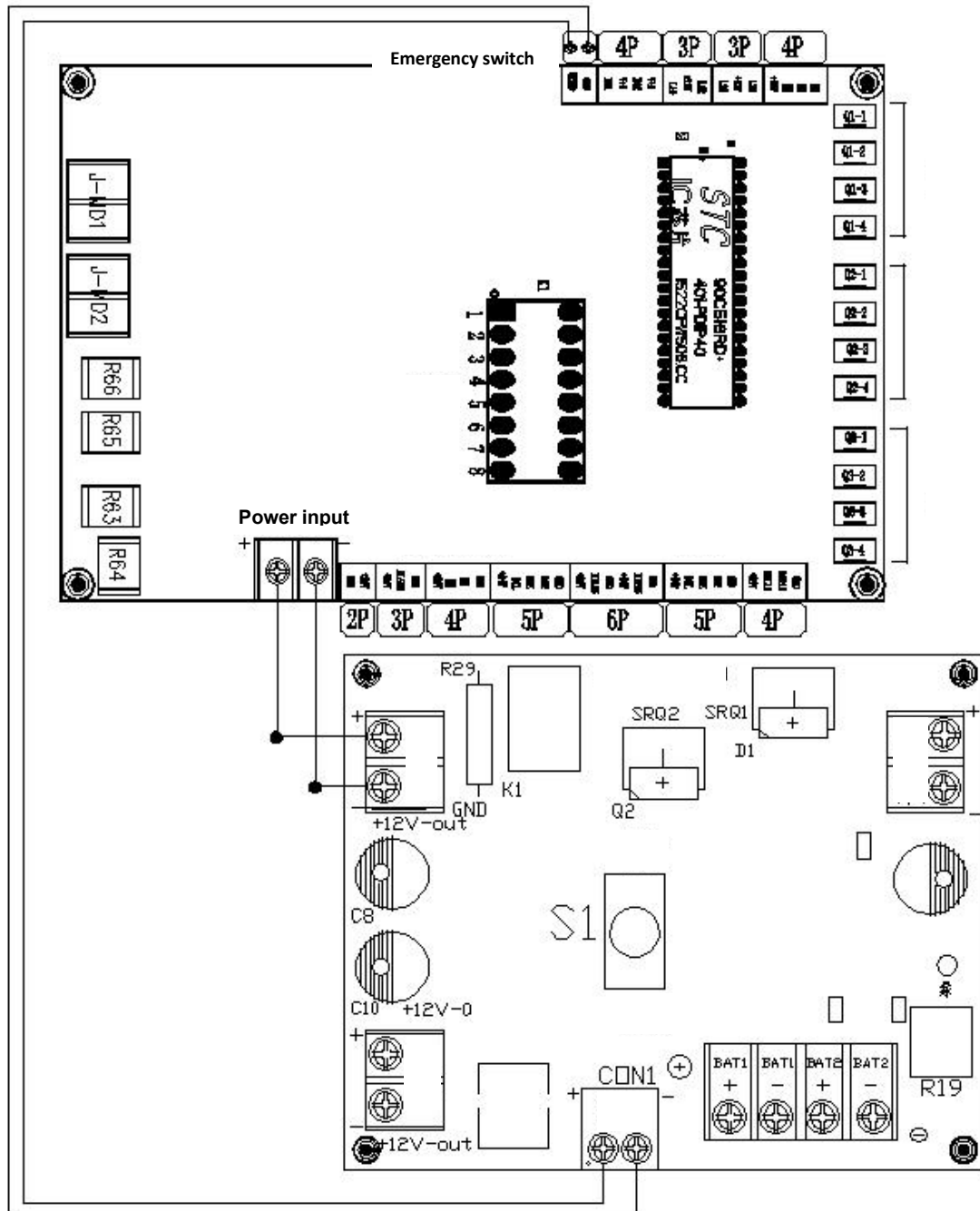

Attached Figure – I Control board connection wiring diagram

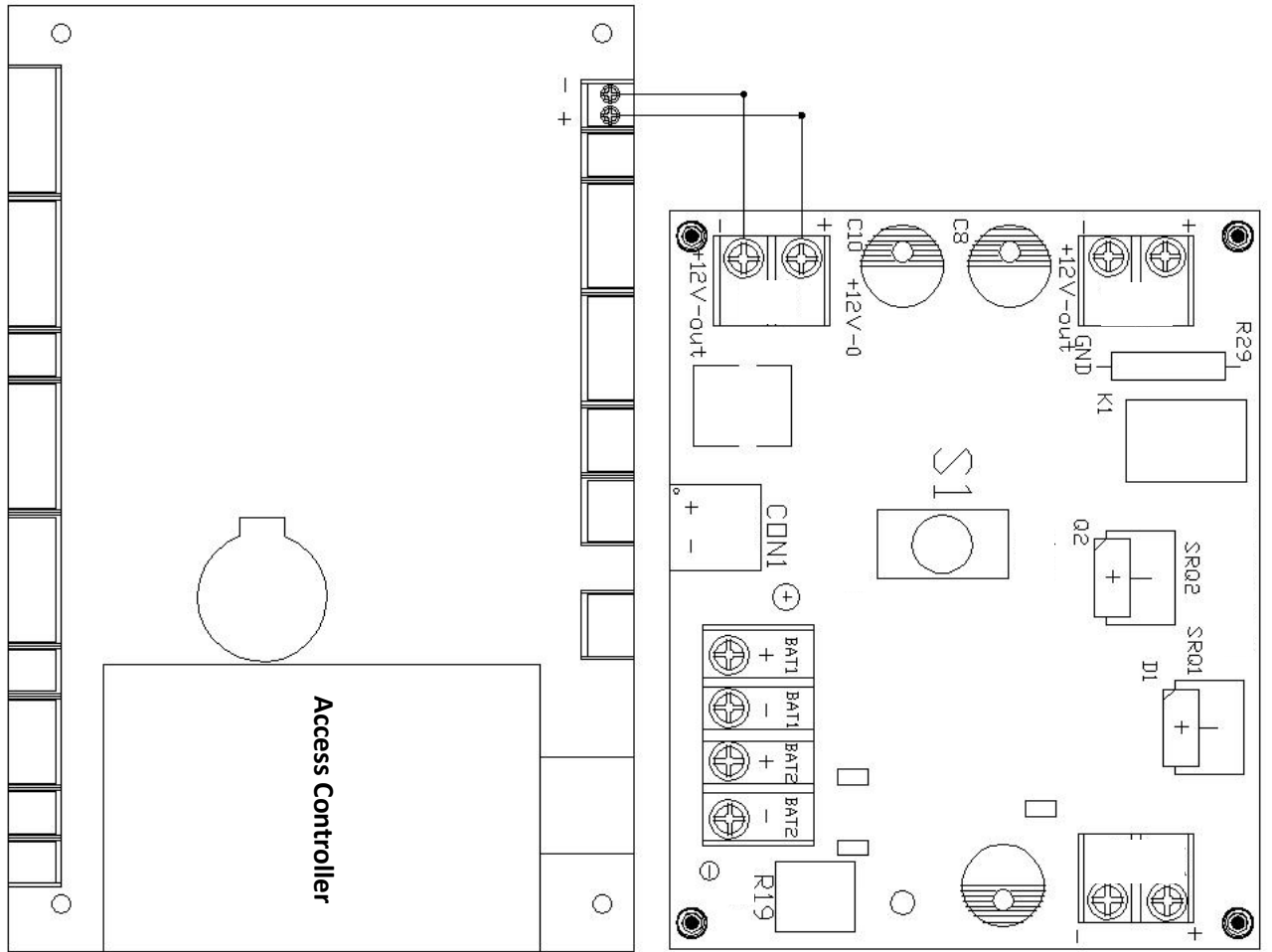

Attached Figure – J Access controller connection wiring diagram

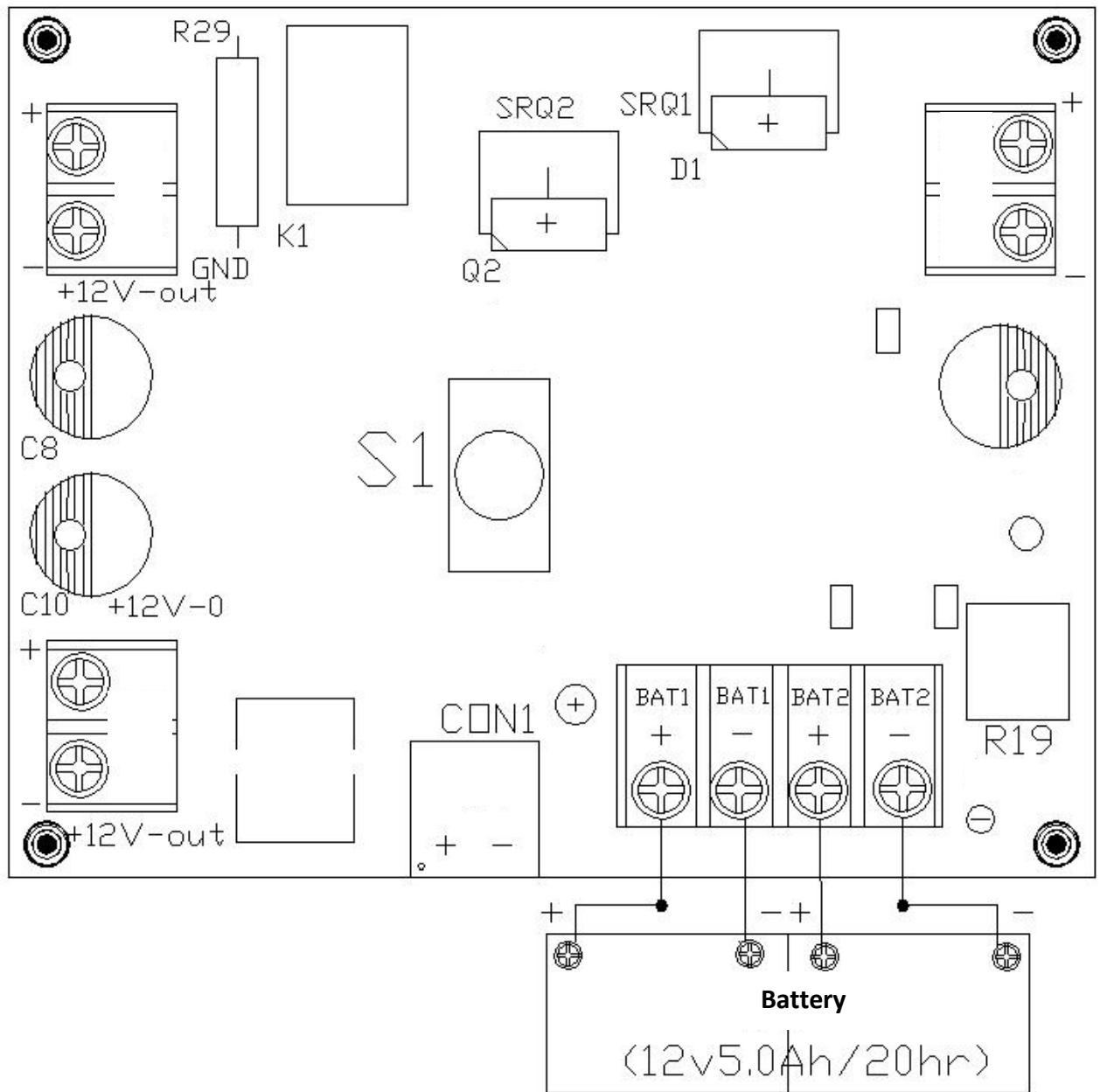

Attached Figure – K Battery connection wiring diagram

12V 5.0Ah/20hr :

12V: Rated voltage of battery;

5Ah: Battery capacity, the battery can work for one hour in the state of 12A, and work for 12 hour in state of 1A ;

20hr: 20 Hour Rate;